

COLLATED QUESTIONS

Hess's Law including application of  $\Delta_r H = \sum \Delta_f H(\text{products}) - \sum \Delta_f H(\text{reactants})$  and related calculations.

2025:2

- (c) Dinitrogen tetroxide,  $\text{N}_2\text{O}_4$ , was reacted with methylhydrazine,  $\text{CH}_3\text{NHNH}_2$ . The equation for the reaction is:

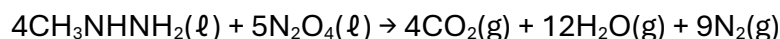

- (i) Calculate the standard enthalpy change of this reaction, using the following data.

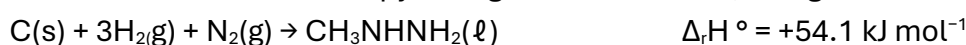

- (ii) Explain the effect on the standard enthalpy change calculated in part (c)(i) if the water was produced as a liquid.

2025:3

- (a) Nitric acid,  $\text{HNO}_3$ , is manufactured from ammonia,  $\text{NH}_3$ . The equation for one of the reactions in the process is:

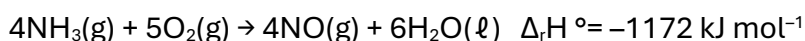

- (i) Write the balanced equation to represent the standard enthalpy of formation of ammonia in the table below.

Substance	Equation	$\Delta_f H^\circ \text{ kJ mol}^{-1}$
$\text{NH}_3(\text{g})$		
$\text{NO}(\text{g})$	$\frac{1}{2} \text{N}_2(\text{g}) + \frac{1}{2} \text{O}_2(\text{g}) \rightarrow \text{NO}(\text{g})$	+90.3
$\text{H}_2\text{O}(\ell)$	$\text{H}_2(\text{g}) + \frac{1}{2} \text{O}_2(\text{g}) \rightarrow \text{H}_2\text{O}(\ell)$	-286

- (ii) Calculate the standard enthalpy of formation for ammonia,  $\Delta_f H^\circ(\text{NH}_3(\text{g}))$ , using the data given in part (i).

**AS91390 Demonstrate understanding of thermochemical principles and the properties of particles and substances**

- (c) When solid calcium chloride,  $\text{CaCl}_2(\text{s})$ , dissolves in water, the temperature increases from  $20.4\text{ }^\circ\text{C}$  to  $23.2\text{ }^\circ\text{C}$ .

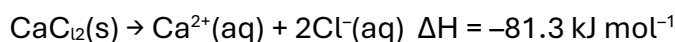

Calculate the mass of  $\text{CaCl}_2(\text{s})$  that must dissolve to cause this temperature increase. Assume the specific heat capacity of the calcium chloride solution is  $4.18\text{ J g}^{-1}\text{ }^\circ\text{C}^{-1}$ . Assume the mass of the calcium chloride solution is  $68.0\text{ g}$ .  $M(\text{CaCl}_2) = 111\text{ g mol}^{-1}$

**2024:1**

- (b) (i) The reaction between chlorine trifluoride,  $\text{ClF}_3(\text{g})$ , and hydrazine,  $\text{N}_2\text{H}_4(\text{l})$ , is explosive. It was investigated as a potential rocket fuel. The reaction is shown below.

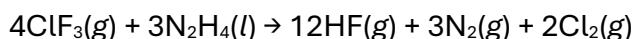

Calculate  $\Delta_r H^\circ$  for the reaction, given the following data.

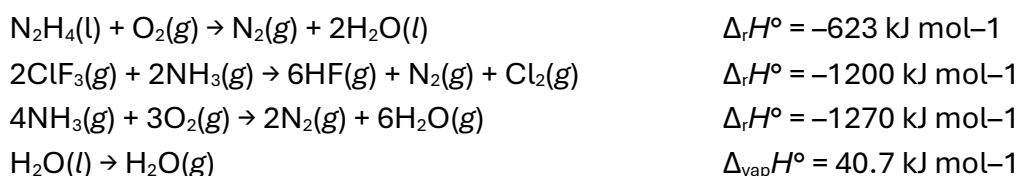

**2024: 3**

- (b) The enthalpy of combustion of ethanol,  $\text{C}_2\text{H}_5\text{OH}$ , was determined experimentally using the apparatus below. The ethanol was completely combusted to heat some water in a beaker.

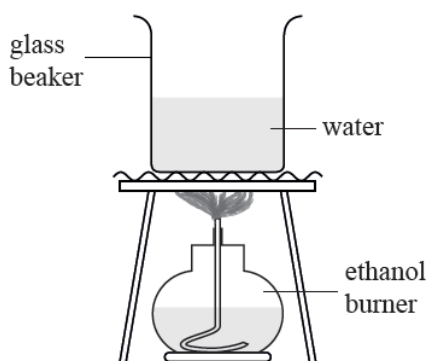

The following data was recorded:

- initial water temperature =  $22.1\text{ }^\circ\text{C}$
- final water temperature =  $31.2\text{ }^\circ\text{C}$
- initial mass of burner and ethanol =  $59.2\text{ g}$
- final mass of burner and ethanol =  $58.7\text{ g}$

The student calculated the experimental enthalpy change for the combustion of liquid ethanol,  $\Delta_c H(\text{C}_2\text{H}_5\text{OH}(\text{l}))$ , to be  $-770\text{ kJ mol}^{-1}$ .

The specific heat capacity of water is  $4.18\text{ J g}^{-1}\text{ }^\circ\text{C}^{-1}$ .  $M(\text{C}_2\text{H}_5\text{OH}) = 46.0\text{ g mol}^{-1}$

**AS91390 Demonstrate understanding of thermochemical principles and the properties of particles and substances**

- (i) Use the information provided to calculate the mass of the water that was in the beaker.
- (ii) Which of these quantities calculated would have been a source of error in the calculated enthalpy value? Circle your answer.

**temperature change of water      mass of fuel combusted**

Explain your choice.

**2023:2**

- (b) (i) The equation below shows the reaction of ammonia,  $\text{NH}_3(\text{g})$  with carbon dioxide,  $\text{CO}_2(\text{g})$  to produce urea,  $\text{CO}(\text{NH}_2)_2(\text{s})$ .

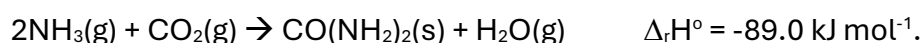

Calculate the standard enthalpy of formation of urea,  $\Delta_f H^\circ(\text{CO}(\text{NH}_2)_2(\text{s}))$ , using the following data.

$$\Delta_f H^\circ(\text{NH}_3(\text{g})) = -46.0 \text{ kJ mol}^{-1}$$

$$\Delta_f H^\circ(\text{CO}_2(\text{g})) = -394 \text{ kJ mol}^{-1}$$

$$\Delta_f H^\circ(\text{H}_2\text{O}(\text{g})) = -242 \text{ kJ mol}^{-1}$$

- (ii) Explain what would happen to  $\Delta_r H^\circ$  provided in part (i) if water was produced as a liquid,  $\text{H}_2\text{O}(\text{l})$ .

**2023:3**

- (c) Glucose,  $\text{C}_6\text{H}_{12}\text{O}_6(\text{s})$ , reacts with oxygen,  $\text{O}_2(\text{g})$ , to produce carbon dioxide,  $\text{CO}_2(\text{g})$ , and water vapour,  $\text{H}_2\text{O}(\text{g})$ , as shown in the equation below:

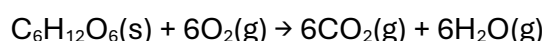

Calculate the enthalpy change for this reaction,  $\Delta_r H^\circ$ , using the following data:

$$\Delta_f H^\circ(\text{C}_6\text{H}_{12}\text{O}_6(\text{s})) = -1270 \text{ kJ mol}^{-1}$$

$$\Delta_c H^\circ(\text{C}(\text{s})) = -394 \text{ kJ mol}^{-1}$$



$$\Delta_{\text{vap}} H^\circ(\text{H}_2\text{O}(\text{l})) = +6.01 \text{ kJ mol}^{-1}$$

**AS91390 Demonstrate understanding of thermochemical principles and the properties of particles and substances**

**2022:1**

- (c) (i) A student burnt 2.28 g of liquid methanol,  $\text{CH}_3\text{OH}(\text{l})$ , to heat 100 g of water. The initial temperature of the water was 20.6 °C.

Once all of the methanol had combusted, the student correctly determined the experimental enthalpy change for the combustion of liquid methanol,  $\Delta_c\text{H}(\text{CH}_3\text{OH}(\text{l}))$ , to be  $-68.6 \text{ kJ mol}^{-1}$ .

The specific heat capacity of water is  $4.18 \text{ J g}^{-1}\text{°C}^{-1}$

$M(\text{CH}_3\text{OH}) = 32.0 \text{ g mol}^{-1}$ ,

Calculate the final temperature that the 100 g of water must have reached in this experiment.

- (ii) The standard enthalpy of combustion of liquid methanol is significantly more exothermic than the experimental value provided in part (i).

Explain TWO reasons for this difference.

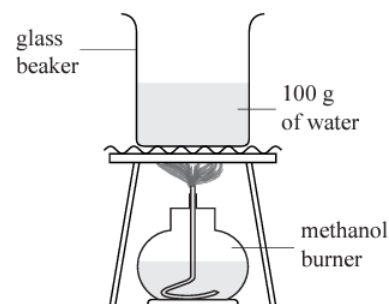

**2022:2**

- (c) When diborane,  $\text{B}_2\text{H}_6$ , reacts with oxygen,  $\text{O}_2$ , it catches fire. The reaction is given below:

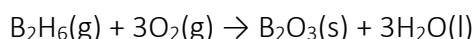

- (i) Calculate the standard enthalpy change,  $\Delta_r\text{H}^\circ$ , for the reaction using the following data:

$$\Delta_f\text{H}^\circ(\text{B}_2\text{H}_6(\text{g})) = +41.0 \text{ kJ mol}^{-1}$$

$$\Delta_f\text{H}^\circ(\text{B}_2\text{O}_3(\text{s})) = -1274 \text{ kJ mol}^{-1}$$

$$\Delta_f\text{H}^\circ(\text{H}_2\text{O}(\text{l})) = -286 \text{ kJ mol}^{-1}$$

**2021: 1**

- (c) (ii) Potassium nitrate,  $\text{KNO}_3$ , readily dissolves in water according to the equation below:



When solid  $\text{KNO}_3$  dissolves in water, the temperature decreases from 21.3 °C to 14.2 °C.

Calculate the mass of solid  $\text{KNO}_3$  that must dissolve to cause this temperature decrease.

Assume the specific heat capacity of potassium nitrate solution is  $4.18 \text{ J g}^{-1}\text{°C}^{-1}$ .

Assume the mass of the potassium nitrate solution is 135 g.  $M(\text{KNO}_3) = 101 \text{ g mol}^{-1}$

**2021:2**

- (c) (i) The equation for the reaction of ammonia,  $\text{NH}_3$ , with oxygen,  $\text{O}_2$ , is given below:

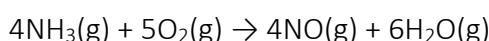

Calculate the standard enthalpy change for this reaction,  $\Delta_r\text{H}^\circ$ , using the following data:



- (ii) Explain why the standard enthalpy change calculated in part (i) would be more exothermic if the water was produced as a liquid.

**AS91390 Demonstrate understanding of thermochemical principles and the properties of particles and substances**

2021:3

(b) (i) Write the equation for the reaction that has an enthalpy change equal to the standard enthalpy of formation,  $\Delta_f H^\circ$ , of solid glucose,  $C_6H_{12}O_6(s)$ .

(ii) Glucose is oxidised during aerobic respiration according to the following equation:

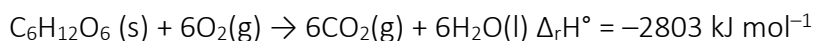

Calculate the standard enthalpy of formation of glucose,  $\Delta_f H^\circ(C_6H_{12}O_6(s))$ , using the following data:  $\Delta_f H^\circ(CO_2(g)) = -394 \text{ kJ mol}^{-1}$   $\Delta_f H^\circ(H_2O(l)) = -286 \text{ kJ mol}^{-1}$ .

2020:1

(b) Solid sodium hydroxide,  $NaOH(s)$ , readily dissolves in water:

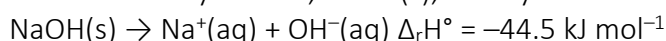

Calculate the temperature change when 1.70 g of solid sodium hydroxide is dissolved in 35.0 g of water. Assume the specific heat capacity of the sodium hydroxide solution is  $4.18 \text{ J g}^{-1} \text{ }^\circ\text{C}^{-1}$ .

Assume the mass of the sodium hydroxide solution is 36.7 g.

$M(NaOH) = 40.0 \text{ g mol}^{-1}$ .

2020:2

(b) (i) Stibine can be oxidised according to the following reaction:

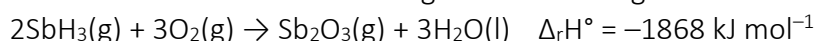

Calculate the standard enthalpy of formation of stibine,  $\Delta_f H^\circ(SbH_3)$ .

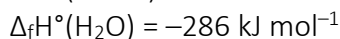
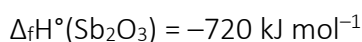

(ii) Explain how the  $\Delta_r H^\circ$  provided in (i) would differ if the water was produced as a gas rather than a liquid.

2019:2

(a) The equation for the vaporisation of hexane is:  $C_6H_{14}(l) \rightarrow C_6H_{14}(g)$

Circle the term that best describes this process: Exothermic Endothermic Give a reason for your choice.

(b) The equation for the formation of liquid hexane is:  $6C(s) + 7H_2(g) \rightarrow C_6H_{14}(l)$

Calculate the standard enthalpy of formation for liquid hexane,  $\Delta_f H^\circ(C_6H_{14}(l))$ , using the following

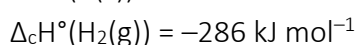
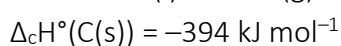
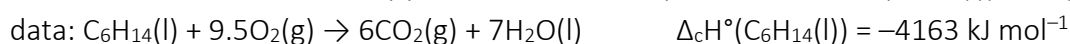

**AS91390 Demonstrate understanding of thermochemical principles and the properties of particles and substances**

(c) The enthalpy of combustion of liquid hexane,  $\Delta_c H(\text{C}_6\text{H}_{14}(\text{l}))$ , can be determined by burning a known mass of hexane and measuring the temperature change in a known mass of water above the burning hexane.

(i) If 5.22 g of hexane is burned, the temperature of 400 g of water increases from 20.5°C to 36.7°C. Using these results, calculate an experimental value of  $\Delta_c H(\text{C}_6\text{H}_{14}(\text{l}))$ . The specific heat capacity of water is  $4.18 \text{ J g}^{-1} \text{ }^\circ\text{C}^{-1}$ .  $M(\text{C}_6\text{H}_{14}) = 86.0 \text{ g mol}^{-1}$

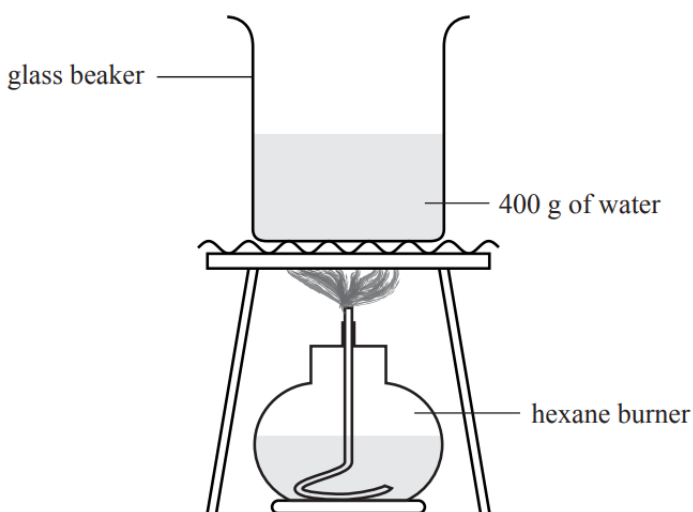

(ii) Explain why the experimental value obtained in part (c)(i) is less negative than the theoretical value of  $-4163 \text{ kJ mol}^{-1}$ , given in part (b).

**2019:3**

(c) Ammonia,  $\text{NH}_3$ , reacts with methane,  $\text{CH}_4$ , in the following reaction:  $\text{CH}_4(\text{g}) + \text{NH}_3(\text{g}) \rightarrow \text{HCN}(\text{g}) + 3\text{H}_2(\text{g})$  Calculate the enthalpy change,  $\Delta_r H^\circ$ , for this reaction using the following data.

$$\Delta_f H^\circ(\text{NH}_3(\text{g})) = -45.9 \text{ kJ mol}^{-1}$$

$$\Delta_f H^\circ(\text{CH}_4(\text{g})) = -74.9 \text{ kJ mol}^{-1}$$

$$\Delta_f H^\circ(\text{HCN}(\text{g})) = +135 \text{ kJ mol}^{-1}$$

**2018:2**

(b) (i) The equation for the combustion of propan-1-ol is:  $\text{C}_3\text{H}_7\text{OH}(\text{l}) + 4.5\text{O}_2(\text{g}) \rightarrow 3\text{CO}_2(\text{g}) + 4\text{H}_2\text{O}(\text{l})$

Calculate the standard enthalpy of combustion,  $\Delta_c H^\circ$ , of propan-1-ol, given the following data:

$$\Delta_f H^\circ(\text{C}_3\text{H}_7\text{OH}(\text{l})) = -255 \text{ kJ mol}^{-1}$$

$$\Delta_f H^\circ(\text{CO}_2(\text{g})) = -394 \text{ kJ mol}^{-1}$$

$$\Delta_f H^\circ(\text{H}_2\text{O}(\text{l})) = -286 \text{ kJ mol}^{-1}$$

(ii) Explain how  $\Delta_c H^\circ(\text{propan-1-ol})$  would differ if water was produced as a gas rather than a liquid.

(c) The equation for the formation of  $\text{Al}_2\text{Cl}_6(\text{s})$  is:

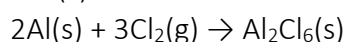

Calculate the enthalpy change,  $\Delta_r H^\circ$ , for this reaction using the following data:

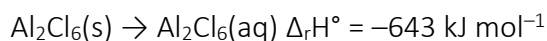
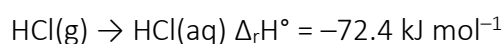
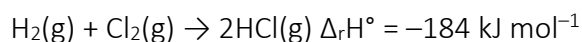
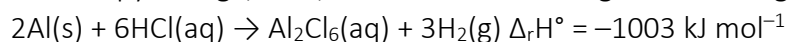

**AS91390 Demonstrate understanding of thermochemical principles and the properties of particles and substances**

**2018:3**

- (a) (i) Write an equation to represent the enthalpy of fusion (melting),  $\Delta_{\text{fus}}H^\circ$ , of water.  
(ii) Why is the enthalpy of vaporisation of water larger than its enthalpy of fusion?
- (b) When 10.6 g of ammonium chloride,  $\text{NH}_4\text{Cl}$ , is dissolved in 65.0 mL of water, the temperature of the water changes from 20.9°C to 11.5°C.  
The mass of the final solution is 75.6 g  
Assume specific heat capacity of aqueous ammonium chloride =  $4.18 \text{ J g}^{-1} \text{ }^\circ\text{C}^{-1}$   
 $M(\text{NH}_4\text{Cl}) = 53.5 \text{ g mol}^{-1}$   
Calculate the enthalpy change,  $\Delta_r H^\circ$ , for dissolving ammonium chloride in water.

**2017:2**

- (c) Carbon dioxide and water are formed when decane burns completely in oxygen. The reaction is shown in the equation below.

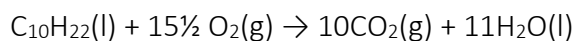

Calculate the enthalpy of combustion for decane, given the following data:

$$\Delta_f H^\circ (\text{C}_{10}\text{H}_{22}(\text{l})) = -301 \text{ kJ mol}^{-1}$$

$$\Delta_c H^\circ (\text{C}) = -393 \text{ kJ mol}^{-1}$$

$$\Delta_c H^\circ (\text{H}_2) = -286 \text{ kJ mol}^{-1}$$

**AS91390 Demonstrate understanding of thermochemical principles and the properties of particles and substances**

2016: 3

- (a) The equation for the combustion of liquid methanol is:

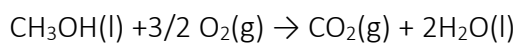

Calculate the standard enthalpy of combustion of liquid methanol,  $\Delta_c H^\circ(\text{CH}_3\text{OH}(\text{l}))$ , using the information in the table below.

Compound	$\text{kJ mol}^{-1}$
$\Delta_c H^\circ(\text{C}(\text{s}))$	-394
$\Delta_c H^\circ(\text{H}_2(\text{g}))$	-286
$\Delta_f H^\circ(\text{CH}_3\text{OH}(\text{l}))$	-240

- (b) The enthalpy of combustion of liquid methanol,  $\Delta_c H^\circ(\text{CH}_3\text{OH}(\text{l}))$ , can also be determined by burning a known mass of methanol and measuring the temperature change in a known mass of water above the burning methanol.

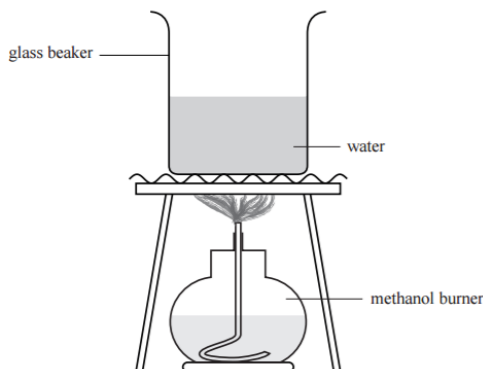

- (i) If 2.56 g of methanol is burned, the temperature of 500 g water increases from 21.2°C to 34.5°C. Using these results, calculate the experimental value of  $\Delta_c H^\circ(\text{CH}_3\text{OH}(\text{l}))$ .  
The specific heat capacity of water is  $4.18 \text{ J }^\circ\text{C}^{-1} \text{ g}^{-1}$ .  $M(\text{CH}_3\text{OH}) = 32.0 \text{ g mol}^{-1}$
- (ii) Why is the experimental value obtained in part (b)(i) less negative than the theoretical value determined in part (a)?
- (iii) The equation for the evaporation of liquid methanol is:  $\text{CH}_3\text{OH}(\text{l}) \rightarrow \text{CH}_3\text{OH}(\text{g})$   
Explain the entropy changes of the system and surroundings for the evaporation of methanol.

2015: 2

The equation for  $\Delta_f H^\circ$  of  $\text{H}_2\text{O}(\text{l})$  is:

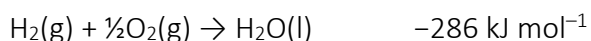

- (a) (i) Write the equation for  $\Delta_c H^\circ(\text{H}_2(\text{g}))$ .  
(ii) Using the equations above, explain why  $\Delta_c H^\circ(\text{H}_2)$  and  $\Delta_f H^\circ(\text{H}_2\text{O})$  have the same value of  $-286 \text{ kJ mol}^{-1}$ .
- (b) The enthalpy of formation would change if the water was formed as a gas rather than a liquid. (i) Circle the correct phrase to complete the sentence below.  $\Delta_f H^\circ(\text{H}_2\text{O}(\text{g}))$  is:  
less negative than / the same as / more negative  
than  $\Delta_f H^\circ(\text{H}_2\text{O}(\text{l}))$ .  
(ii) Justify your choice

**AS91390 Demonstrate understanding of thermochemical principles and the properties of particles and substances**

(c) Calculate the  $\Delta_f H^\circ$  for  $B_2H_6(g)$ , given the following data:

$$\Delta_f H^\circ (B_2O_3(s)) = -1255 \text{ kJ mol}^{-1}$$

$$\Delta_f H^\circ (H_2O(l)) = -286 \text{ kJ mol}^{-1}$$

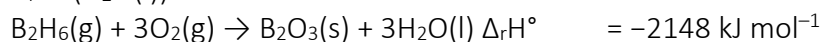

**2015: 3**

(d) The equation for the combustion of pentan-1-ol is:

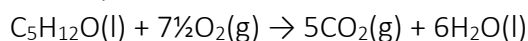

Calculate  $\Delta_c H^\circ$  for pentan-1-ol, given the following data:

$$\Delta_f H^\circ (C_5H_{12}O(l)) = -295 \text{ kJ mol}^{-1}$$

$$\Delta_f H^\circ (CO_2(g)) = -394 \text{ kJ mol}^{-1}$$

$$\Delta_f H^\circ (H_2O(l)) = -286 \text{ kJ mol}^{-1}$$

**2014: 2**

(c) An equation for the reaction of ammonia gas with hydrogen chloride gas is:

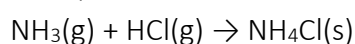

Calculate the standard enthalpy change,  $\Delta_r H^\circ$ , for this reaction, using the following data.

$$\Delta_f H^\circ (NH_3(g)) = -46 \text{ kJ mol}^{-1}$$

$$\Delta_f H^\circ (HCl(g)) = -92 \text{ kJ mol}^{-1}$$

$$\Delta_f H^\circ (NH_4Cl(s)) = -314 \text{ kJ mol}^{-1}$$

**2014: 3**

(d) (i)

Compound	$\text{kJ mol}^{-1}$
$\Delta_c H^\circ (C(s))$	-394
$\Delta_f H^\circ (H_2O(l))$	-286
$\Delta_c H^\circ C_2H_5OH(l)$	-1367

Calculate the standard enthalpy of formation of liquid ethanol using the information given above.

(ii) Discuss how the value of the enthalpy change would differ if the ethanol product formed was a gas rather than a liquid. No calculation is necessary.

**2013: 2**

(a) (ii) When gaseous hydrogen and oxygen are heated in a test tube, droplets of liquid water form on the sides of the test tube. Calculate  $\Delta_f H^\circ(H_2O(l))$ , given the following data:

$$\Delta_f H^\circ(H_2O(g)) = -242 \text{ kJ mol}^{-1}$$

$$\Delta_{\text{vap}} H^\circ(H_2O(l)) = +44 \text{ kJ mol}^{-1}$$

(b) (i) When 25.0 mL of a 1.00 mol L<sup>-1</sup> hydrochloric acid solution, HCl, is added to 25.0 mL of a 1.00 mol L<sup>-1</sup> ammonia solution, NH<sub>3</sub>, a temperature rise of 6.50°C is recorded, as a neutralisation reaction occurs to produce aqueous ammonium chloride and water.

Calculate  $\Delta_r H^\circ$  for this neutralisation reaction.

The mass of the mixture is 50.0 g.

Assume specific heat capacity of the aqueous ammonium chloride = 4.18 J g<sup>-1</sup> °C<sup>-1</sup>

**AS91390 Demonstrate understanding of thermochemical principles and the properties of particles and substances**

- (ii) When the  $\Delta_r H^\circ$  for the neutralisation above was found experimentally in a school laboratory, the value obtained was lower than the theoretical value.  
Account for the difference in values, and suggest how this difference could be minimised.

**2013: 3**

- (b) Decane is a component of petrol. Carbon dioxide and water are formed when decane burns completely in oxygen.

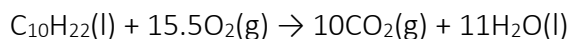

Calculate  $\Delta_c H^\circ(\text{C}_{10}\text{H}_{22}(\text{l}))$ , given the following data:

$$\begin{aligned} \Delta_f H^\circ(\text{C}_{10}\text{H}_{22}(\text{l})) &= -250 \text{ kJ mol}^{-1} \\ \Delta_f H^\circ(\text{CO}_2(\text{g})) &= -393 \text{ kJ mol}^{-1} \\ \Delta_f H^\circ(\text{H}_2\text{O}(\text{l})) &= -286 \text{ kJ mol}^{-1} \end{aligned}$$

**2012:3**

- (a) (i) Explain what is meant by the symbol  $\Delta_c H^\circ$   
(ii) An equation for the combustion of octane is:

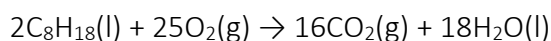

Calculate  $\Delta_c H^\circ(\text{C}_8\text{H}_{18}(\text{l}))$ , given the following data:

$$\begin{aligned} \Delta_f H^\circ(\text{C}_8\text{H}_{18}(\text{l})) &= -250 \text{ kJ mol}^{-1} \\ \Delta_f H^\circ(\text{CO}_2(\text{g})) &= -394 \text{ kJ mol}^{-1} \\ \Delta_f H^\circ(\text{H}_2\text{O}(\text{l})) &= -286 \text{ kJ mol}^{-1} \end{aligned}$$

- (b) The equation for the combustion of propan-1-ol is:

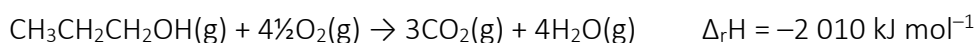

Calculate the bond enthalpy for the C=O bond, using the enthalpy of the reaction above and the bond enthalpy data in the table.

Bond	Bond enthalpy / $\text{kJ mol}^{-1}$
C-H	+414
C-O	+358
O=O	+498
C-C	+346
O-H	+463

- (c) Define bond enthalpy and explain why the bond enthalpy value calculated for C=O is higher than the C-O bond enthalpy.

**AS91390 Demonstrate understanding of thermochemical principles and the properties of particles and substances**

2011:3

- (c) The equation for the combustion of ethanol is:  $\text{C}_2\text{H}_5\text{OH}(\text{l}) + 3\text{O}_2(\text{g}) \rightarrow 2\text{CO}_2(\text{g}) + 3\text{H}_2\text{O}(\text{l})$

Calculate  $\Delta_c H^\circ$  ( $\text{C}_2\text{H}_5\text{OH}(\text{l})$ ), given the following data:

$$\Delta_f H^\circ (\text{C}_2\text{H}_5\text{OH}(\text{l})) = -277 \text{ kJ mol}^{-1}$$

$$\Delta_f H^\circ (\text{CO}_2(\text{g})) = -394 \text{ kJ mol}^{-1}$$

$$\Delta_f H^\circ (\text{H}_2\text{O}(\text{l})) = -286 \text{ kJ mol}^{-1}$$

2011:4

- (a) Explain why  $\Delta_f H^\circ (\text{CO}_2(\text{g}))$  and  $\Delta_c H^\circ (\text{C}(\text{s}))$  have the same value of  $-394 \text{ kJ mol}^{-1}$ .  
 (b) Complete combustion of methanol can be represented by the following chemical equation:

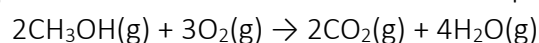

Use the following bond enthalpies to calculate  $\Delta_r H$  for this reaction.

Bond	Bond enthalpy / $\text{kJ mol}^{-1}$
C-H	+414
C-O	+358
O-H	+463
C=O	+745
O=O	+498

- (c) (i) Use the information below to show that the  $\Delta_c H^\circ$  of propene,  $\text{CH}_2=\text{CHCH}_3(\text{g})$ , is  $-2058 \text{ kJ mol}^{-1}$ .  
 $\text{C} \quad \text{CH}_2=\text{CHCH}_3(\text{g}) + \text{H}_2(\text{g}) \rightarrow \text{CH}_3\text{CH}_2\text{CH}_3(\text{g}) \quad \Delta_f H^\circ = -124 \text{ kJ mol}^{-1}$   
 $\text{CH}_3\text{CH}_2\text{CH}_3(\text{g}) \quad \Delta_c H^\circ = -2220 \text{ kJ mol}^{-1}$   
 $\text{H}_2\text{O}(\text{l}) \quad \Delta_f H^\circ = -286 \text{ kJ mol}^{-1}$
- (ii) The  $\Delta_c H^\circ$  of propene was found experimentally in a school laboratory to be  $-1368 \text{ kJ mol}^{-1}$ . The theoretical value is  $-2058 \text{ kJ mol}^{-1}$ . Account for the difference in values, and suggest how this difference could be minimised.

Answers

2025:2

- (c) (i)  $(-54.1 \times 4) + (-394 \times 4) + (20.0 \times 5) + (-286 \times 12) + (40.7 \times 12) = -4636$   
 $= -4640 \text{ kJ mol}^{-1}$
- (ii) The enthalpy change would be more exothermic / negative because heat energy would be released as intermolecular forces form between liquid water molecules.

2025:3

- (a) (i)  $\frac{1}{2}\text{N}_2(\text{g}) + 1\frac{1}{2}\text{H}_2(\text{g}) \rightarrow \text{NH}_3(\text{g})$ .
- (ii)  $-1172 = ((4 \times 90.3) + (6 \times -286)) - (4 \times x)$   
 $\Delta_f H^\circ(\text{NH}_3(\text{g})) = -45.7 \text{ kJ mol}^{-1}$
- (c)  $q = 68.0 \times 4.18 \times (23.2 - 20.4) = 795.9 \text{ J}$   
 $= 0.7959 \text{ kJ}$   
 $n = -q / \Delta H = -0.7959 / -81.3 = 9.79 \times 10^{-3} \text{ mol}$   
 $m(\text{CaCl}_2) = n \times M = 9.79 \times 10^{-3} \times 111 = 1.09 \text{ g}$

2024:1

- (b) (i)  $3\text{N}_2\text{H}_4(\text{l}) + 3\text{O}_2(\text{g}) \rightarrow 3\text{N}_2(\text{g}) + 6\text{H}_2\text{O}(\text{l})$  -623 x 3  
 $4\text{ClF}_3(\text{g}) + 4\text{NH}_3(\text{g}) \rightarrow 12\text{HF}(\text{g}) + 2\text{N}_2(\text{g}) + 2\text{Cl}_2(\text{g})$  -1200 x 2  
 $2\text{N}_2(\text{g}) + 6\text{H}_2\text{O}(\text{g}) \rightarrow 4\text{NH}_3(\text{g}) + 3\text{O}_2(\text{g})$  (reverse) +1270  
 $6\text{H}_2\text{O}(\text{l}) \rightarrow 6\text{H}_2\text{O}(\text{g})$  +40.7 x 6

$$\Delta_r H = -1869 + -2400 + 1270 + 244.2 = -2754.8 = -2750 \text{ kJ mol}^{-1}$$

2024:3

- (b) (i)  $n(\text{C}_2\text{H}_5\text{OH}) = m/M = 0.500 / 46.0 = 0.0109 \text{ mol}$   
 $-q = \Delta_r H \times n = -770 \times 0.0109 = -8.37 \text{ kJ}$   
 Therefore  $q = 8.37 \text{ kJ} = 8370 \text{ J}$   
 $m = q / c\Delta t = 8370 / (4.18 \times 9.1) = 220 \text{ g}$
- (ii) Identifies temperature change of water.  
 The temperature change (rise) as beaker is not insulated / no lid / heat escaping round the sides, therefore less heat is transferred to the water than should be.  
 Heat loss to the gauze (and beaker), therefore less heat is transferred to the water than should be.

2023:2

- (b) (i)  $-89.0 = [\Delta_f H^\circ(\text{CO}(\text{NH}_2)_2) + (-242)] - [(2 \times -46.0) + -394]$   
 $-89.0 = \Delta_f H^\circ(\text{CO}(\text{NH}_2)_2) + 244$   
 $\Delta_f H^\circ(\text{CO}(\text{NH}_2)_2) = -89.0 - 244$   
 $\Delta_f H^\circ(\text{CO}(\text{NH}_2)_2) = -333 \text{ kJ mol}^{-1}$

**AS91390 Demonstrate understanding of thermochemical principles and the properties of particles and substances**

- (ii) If liquid water was produced instead of gaseous water, heat energy would be released as (intermolecular) bonds form between the liquid water molecules. As a result, the enthalpy change would be more negative / more exothermic. (in reverse – less energy is required to turn liquid water to a gas so more energy is released and therefore more exothermic).

**2023:3**

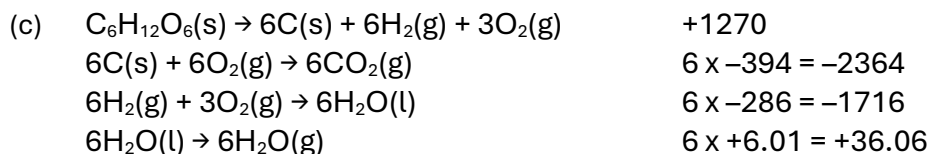

$$\Delta_r H = +1270 + (-2364) + (-1716) + (+36.06) = -2774 \text{ kJ mol}^{-1}$$

**2022:1**

- (c) (i)  $n(\text{CH}_3\text{OH}) = m/M = 2.28/32.0 = 0.07125 \text{ mol}$   
 $-q = \Delta H \times n = -68.6 \times 0.07125 = -4.89 \text{ kJ}$   
 Therefore  $q = 4.89 \text{ kJ} = 4890 \text{ J}$   
 $\Delta T = q/mc = 4890/(100 \times 4.18)$   
 $\Delta T = 11.7 \text{ }^\circ\text{C}$   
 Therefore final temperature =  $20.6 + 11.7 = 32.3 \text{ }^\circ\text{C}$
- (ii) The beaker is not insulated / no lid / heat escaping round the sides therefore less heat is transferred to the water than should be. Some incomplete combustion occurred therefore less heat energy is released than complete combustion. Not done at standard conditions

**2022:2**

- (c) (i)  $\Delta_r H^\circ = [(-1274) + (3 \times -286)] - (+41.0)$   
 $= -2173 \text{ kJ mol}^{-1} (-2170)$

**2021:1**

- (d) (ii)
- $$q = mc\Delta T$$
- $$= 135 \times 4.18 \times (14.2 - 21.3)$$
- $$= -4007 \text{ J}$$
- $$= -4.007 \text{ kJ}$$
- $$\Delta H = -\frac{q}{n}$$
- $$n = -\frac{-4.007}{34.9}$$
- $$n = 0.115 \text{ mol}$$
- $$m = nM$$
- $$= 0.115 \times 101$$
- $$= 11.6 \text{ g}$$

**AS91390 Demonstrate understanding of thermochemical principles and the properties of particles and substances**

**2021:2**

(c) (i)

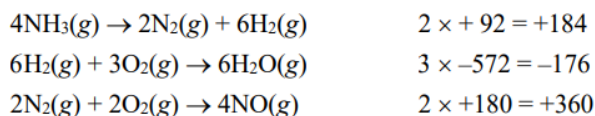

$$\Delta_r H = (+184) + (-176) + (+360) = -1172 \text{ kJ mol}^{-1} \text{ (-1170 3sf)}$$

(ii) The enthalpy change would be more exothermic because heat energy would be released as intermolecular forces form between liquid water molecules.

**2021:3**

(c) (i)  $6\text{C}(\text{s}) + 6\text{H}_2(\text{g}) + 3\text{O}_2(\text{g}) \rightarrow \text{C}_6\text{H}_{12}\text{O}_6(\text{s})$

(ii)

$$-2803 = [(6 \times -394) + (6 \times -286)] - \Delta_f H^\circ(\text{C}_6\text{H}_{12}\text{O}_6)$$

$$-2803 = [(-2364) + (-1716)] - \Delta_f H^\circ(\text{C}_6\text{H}_{12}\text{O}_6)$$

$$\Delta_f H^\circ(\text{C}_6\text{H}_{12}\text{O}_6) = -1277 \text{ kJ mol}^{-1} \text{ (1280 3sf)}$$

**2020:1**

$$-q = \Delta H \times n = -44.5 \times \frac{1.70}{40.0}$$

$$q = 1.891 \text{ kJ} = 1891 \text{ J} \quad (n = 0.0425 \text{ mol})$$

$$\Delta T = \frac{q}{mc} = \frac{1891}{36.7 \times 4.18} = 12.3 \text{ }^\circ\text{C}$$

(b)

**2020:2**

(b) (i)  $-1868 = [-720 + (3 \times -286)] - 2\Delta_f H^\circ(\text{SbH}_3)$

$$-1868 = -1578 - 2\Delta_f H^\circ(\text{SbH}_3)$$

$$2\Delta_f H^\circ(\text{SbH}_3) = +290$$

$$\Delta_f H^\circ(\text{SbH}_3) = +145 \text{ kJ mol}^{-1}$$

(ii) The enthalpy change would be less negative / less exothermic/  $\Delta_f H^\circ$  increase. Energy is absorbed / required to break the intermolecular attractions when changing liquid water into gaseous water. As a result, less heat energy will be released in the reaction. OR Less energy is released when forming gaseous water rather than liquid water because fewer intermolecular attractions are formed.

**2019:2**

(a) Endothermic since energy is required to break the intermolecular forces between the molecules in the liquid state.

(b) Find  $6\text{C}(\text{s}) + 7\text{H}_2(\text{g}) \rightarrow \text{C}_6\text{H}_{14}(\ell)$

$$6\text{C}(\text{s}) + 6\text{O}_2(\text{g}) \rightarrow 6\text{CO}_2(\text{g}) = 6 \times -394 \text{ kJ mol}^{-1} = -2364 \text{ kJ mol}^{-1}$$

$$\text{H}_2(\text{g}) + \frac{1}{2}\text{O}_2(\text{g}) \rightarrow \text{H}_2\text{O}(\text{g}) = 7 \times -286 \text{ kJ mol}^{-1} = -2002 \text{ kJ mol}^{-1}$$

$$6\text{CO}_2(\text{g}) + 7\text{H}_2\text{O}(\ell) \rightarrow \text{C}_6\text{H}_{14}(\ell) + 9\frac{1}{2}\text{O}_2(\text{g}) = (\text{reverse}) = +4163 \text{ kJ mol}^{-1}$$

$$\Delta_f H^\circ(\text{C}_6\text{H}_{14}) = -2364 + -2002 + 4163 = -203 \text{ kJ mol}^{-1}$$

**AS91390 Demonstrate understanding of thermochemical principles and the properties of particles and substances**

- (c) (i)  $q = mc\Delta T = 400 \times 4.18 \times (36.7 - 20.5) = 27086 \text{ J} = 27.086 \text{ kJ}$   
 $n(\text{C}_6\text{H}_{14}) = 5.22/86.0 = 0.0607 \text{ mol}$   
 $\Delta_r H = -q/n = -27.086/0.0607 = -446 \text{ kJ mol}^{-1}$
- (ii) Less negative as a result of heat loss to the surroundings / some incomplete combustion occurring / apparatus absorbing heat / not done in standard conditions resulting in less energy being transferred to the water.

**2019:3**

- (c)  $\Delta_r H^\circ = \sum \Delta_f H^\circ (\text{products}) - \sum \Delta_f H^\circ (\text{reactants})$   
 $+135 - (-74.9 + -45.9) = +256 \text{ kJ mol}^{-1}$

**2018:2**

- (b) (i)  $\Delta_c H^\circ = [(3 \times -394) + (4 \times -286)] - (-255) = -2071 \text{ kJ mol}^{-1}$
- (ii) The enthalpy change would be less negative / less exothermic. Energy is absorbed/required to break the intermolecular attractions when changing liquid water into gaseous water / less bonds are formed when gaseous water is produced As a result, less heat energy will be released in the reaction.

- (c)  $2\text{Al(s)} + 6\text{HCl(aq)} \rightarrow \text{Al}_2\text{Cl}_6(\text{aq}) + 3\text{H}_2(\text{g}) \quad -1003$   
 $3\text{H}_2(\text{g}) + 3\text{Cl}_2(\text{g}) \rightarrow 6\text{HCl(g)} \quad -552$   
 $6\text{HCl(g)} \rightarrow 6\text{HCl(aq)} \quad -434.4$   
 $\text{Al}_2\text{Cl}_6(\text{aq}) \rightarrow \text{Al}_2\text{Cl}_6(\text{s}) \quad +643$
- $2\text{Al(s)} + 3\text{Cl}_2(\text{g}) \rightarrow \text{Al}_2\text{Cl}_6(\text{s}) \quad -1346.4 \text{ kJ mol}^{-1} (-1350 \text{ kJ mol}^{-1})$

**2018:3**

- (a) (i)  $\text{H}_2\text{O(s)} \rightarrow \text{H}_2\text{O(l)}$
- (ii) The enthalpy of vaporisation is larger than the enthalpy of fusion since much more heat energy is required to break all the attractive forces between liquid particles to form a gas. When a solid changes into a liquid, only some of the attractive forces are overcome, so less heat energy is required.
- (iii)  $q = mc\Delta T$   
 $q = 75.6 \times 4.18 (11.5 - 20.9)$   
 $q = -2970.5 \text{ J}$   
 $q = -2.9705 \text{ kJ}$   
 $n(\text{NH}_4\text{Cl}) = m/M = 10.6/53.5 = 0.1981 \text{ mol}$   
 $\Delta H = -q/n = -2.9705/0.198 = +15.0 \text{ kJ mol}^{-1}$

**2017: 2**

- (c)  $10\text{C} + 11\text{H}_2 \rightarrow \text{C}_{10}\text{H}_{22} \quad -301 \text{ kJ mol}^{-1}$   
 $\text{C} + \text{O}_2 \rightarrow \text{CO}_2 \quad -393 \times 10 \text{ kJ mol}^{-1}$   
 $\text{H}_2 + \frac{1}{2}\text{O}_2 \rightarrow \text{H}_2\text{O} \quad -286 \times 11 \text{ kJ mol}^{-1}$   
 $\Delta H = +301 + (10 \times -393) + (11 \times -286) = -6775 \text{ kJ mol}^{-1}$

**AS91390 Demonstrate understanding of thermochemical principles and the properties of particles and substances**

2016: 3

(a)  $\Delta_c H^\circ = -394 + (2 \times -286) - (-240)$

$\Delta_c H^\circ = -966 + 240$

$\Delta_c H^\circ = -726 \text{ kJ mol}^{-1}$

(b) (i)  $q = mc\Delta T$

$q = 500 \text{ g} \times 4.18 \text{ J }^\circ\text{C}^{-1} \text{ g}^{-1} \times (34.5^\circ\text{C} - 21.2^\circ\text{C})$

$q = 27\,797 \text{ J} = 27.797 \text{ kJ}$

$n(\text{CH}_3\text{OH}) = m/M = 2.56/32 = 0.08 \text{ mol}$

$\Delta_c H = -q / n = -27.797 / 0.08 = -347 \text{ kJ mol}^{-1}$

(ii) Heat loss to surroundings / incomplete combustion which means the temperature of the water doesn't increase as much leading to a less negative enthalpy / the experiment wasn't insulated.

(iii) Entropy

There is an increase in entropy since gaseous particles are formed; gaseous particles have a more random / disordered arrangement (greater dispersal of matter) than liquid particles.

The enthalpy of the surroundings decreases as the alcohol evaporates as energy is absorbed from the surroundings to break the intermolecular forces between methanol molecules; thus the entropy of the surroundings decreases.

2015: 2

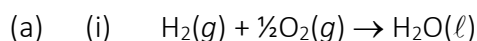

(ii) The equation for the combustion of hydrogen is the same as the equation for the heat of formation of water.

(b) (i) The  $\Delta_f H^\circ (\text{H}_2\text{O}(\text{g}))$  will be **less negative** than  $\Delta_f H^\circ (\text{H}_2\text{O}(\ell))$ .

(ii) Making bonds releases energy. As less bonding is present in water as a gas than a liquid then less energy will be released when gaseous water is formed thus the  $\Delta_f H^\circ (\text{H}_2\text{O}(\text{g}))$  will be less negative.

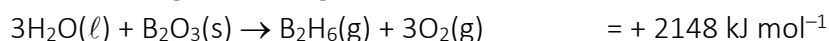
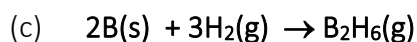

---

$= + 35 \text{ kJ mol}^{-1}$

2015: 3

(d)  $\Delta_c H^\circ = \Sigma \Delta_f H^\circ (\text{products}) - \Sigma \Delta_f H^\circ (\text{reactants})$

$= [(5 \times -394) + (6 \times -286)] - [-295]$

$= -3686 + 295 \quad = -3391 \text{ kJ mol}^{-1}$

2014:2

(c)  $\Delta_r H^\circ = \Sigma \Delta_f H^\circ \text{ products} - \Sigma \Delta_f H^\circ \text{ reactants}$

$= (-314) - (-46 + -92) \quad = -176 \text{ kJ mol}^{-1}$

**AS91390 Demonstrate understanding of thermochemical principles and the properties of particles and substances**

2014:3

(d) (i)

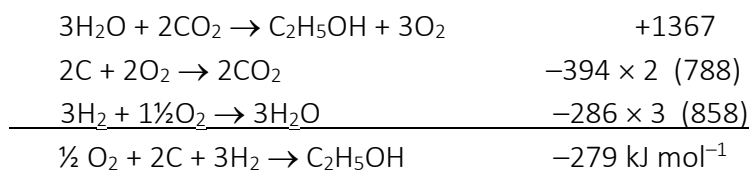

- (ii) The enthalpy change would be more positive. Heat energy is absorbed when converting a liquid to a gas. Therefore, if the ethanol formed were in the gaseous state, less energy would be released in its formation / products would have a higher enthalpy.

2013:2

(a) (ii)

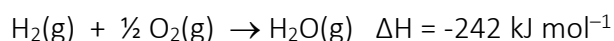
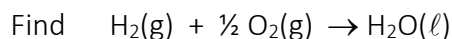

$\Delta_r H^\circ(\text{H}_2\text{O}(\ell)) = -44 + (-242) = -286 \text{ kJ mol}^{-1}$

2013:2

(b) (i)

$q = mc\Delta T = 50 \times 4.18 \times 6.5 = 1358.5 \text{ J} = 1.3585 \text{ kJ}$

$n = c \times V = 1 \times 0.025 = 0.025 \text{ mol}$

$\Delta_r H^\circ = \frac{-q}{n} = \frac{-1.3585 \text{ kJ}}{0.025 \text{ mol}}$

$= -54.3 \text{ kJ mol}^{-1}$

- (ii) Conditions were not standard.  
 Needed to carry out under standard conditions.  
 OR Heat lost to atmosphere / beaker / surroundings.  
 Insulate equipment; ensure all / as much of the energy produced as possible is collected and measured.

2012:3

(a) (i)

The heat evolved / energy change when one mole of a substance is combusted / burnt in oxygen / reacted completely in oxygen under standard conditions

(ii)



$-10\ 952 / 2 = -5476 \text{ kJ mol}^{-1}$

OR

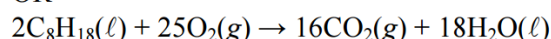

$\Delta_r H^\circ = \Sigma \Delta_f H^\circ_{\text{products}} - \Sigma \Delta_f H^\circ_{\text{reactants}}$   
 $= 16(-394) + 18(-286) - 2(-250) = -10952 \text{ kJ mol}^{-1}$

$\Delta_c H^\circ = -10952 / 2 = -5476 \text{ kJ mol}^{-1}$

**AS91390 Demonstrate understanding of thermochemical principles and the properties of particles and substances**

(b)

$$\text{Enthalpy change} = \Sigma(\text{bonds broken}) - \Sigma(\text{bonds formed})$$

$$x = E_{(\text{C}=\text{O})}$$

$$\text{Bonds broken} = 7(\text{C-H}) + 2(\text{C-C}) + 1(\text{C-O}) + 1(\text{O-H}) + 4.5(\text{O=O})$$

$$= 7(414) + 2(346) + 358 + 463 + 4.5(498)$$

$$= 2898 + 692 + 358 + 463 + 2241$$

$$\text{Bonds broken} = 6652 \text{ kJ mol}^{-1}$$

$$\text{Bonds formed} = 6(\text{C=O}) + 8(\text{O-H})$$

$$= 6(x) + 8(463)$$

$$= 6(x) + 3704$$

$$-2010 = (6652) - (6(x) + 3704)$$

$$-2010 = 2948 - 6(x)$$

$$-4958 = -6(x)$$

$$E_{(\text{C}=\text{O})} = \mathbf{826 \text{ kJ mol}^{-1}} \text{ OR } \mathbf{826.3 \text{ kJ mol}^{-1}}$$

- (c) The bond enthalpy is the energy required to break one mole of bonds between (pairs of) atoms (in the gaseous state). C=O bond enthalpy is larger than C-O bond enthalpy as more energy is required to break the double bond than a single bond.

**2011:3**

(c)

$$\Delta_r H = \Sigma \Delta_f H^\circ (\text{products}) - \Sigma \Delta_f H^\circ (\text{reactants})$$

$$= [(2 \times -394) + (3 \times -286)] - [-277]$$

$$= -1646 + 277$$

$$= -1369 \text{ kJ mol}^{-1}$$

**AS91390 Demonstrate understanding of thermochemical principles and the properties of particles and substances**

2011:4

- (a)  $\Delta_f H^\circ$  ( $\text{CO}_2(\text{g})$ ) is equal to the enthalpy change for the reaction in which one mole of  $\text{CO}_2(\text{g})$  is formed from its elements in their standard state.  $\text{C}(\text{s}) + \text{O}_2(\text{g}) \rightarrow \text{CO}_2(\text{g})$ .  
This is also the equation for  $\Delta_c H^\circ$  ( $\text{C}(\text{s})$ ), the combustion of one mole of carbon under standard conditions.

- (b) (i) (a)  $\text{C}_3\text{H}_6 + 4\frac{1}{2} \text{O}_2 \rightarrow 3\text{CO}_2 + 3\text{H}_2\text{O}$

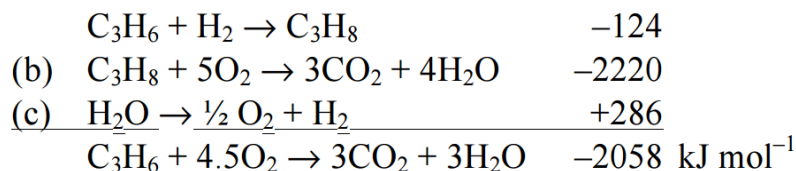

- (ii) Conditions were not standard. Carry out under standard conditions.  
Heat lost to atmosphere / beaker / by evaporation. Insulate equipment, ensure all / as much as possible, of the energy produced is collected and measured.  
Not complete combustion – make sure  $\text{O}_2$  supply sufficient for complete combustion.