

NAME:

SCIENCE TEACHER: (circle code)

10B

SCIENCE

Year 10 Examination 2013

10B – 80 marks

Make sure you have answered all the questions in this paper before you start 10A or 10C

Time allowed for both examinations: 2 hours

Answer all questions in the spaces provided on the paper.

Show all your working in calculations.

Give units for all answers (eg kg or m) unless they are already provided.

Check you have pages 1-14.

For Teacher Use

<i>Question</i>	<i>m/c</i>	<i>Short answers 1-19</i>	<i>Total</i>
<i>Marks gained</i>			
<i>Marks available</i>	30	50	80

Thinking with evidence in Science - Multiple Choice Questions

- Use a **blue or black pen**
- For each answer **completely fill in the circle** as shown. A ○ B ● C ○ D ○
- Do **not** extend beyond the circles.
- If you want to change your answer **you must** cross out your original answer as shown. A ○ B ✕ C ○ D ●
- If you change your mind about an answer you have crossed out and now want to choose it, draw a ring around the cross as shown. A ○ B ⊗ C ○ D ✕

1 A ○ B ○ C ○ D ○

2 A ○ B ○ C ○ D ○

3 A ○ B ○ C ○ D ○

4 A ○ B ○ C ○ D ○

5 A ○ B ○ C ○ D ○

6 A ○ B ○ C ○ D ○

7 A ○ B ○ C ○ D ○

8 A ○ B ○ C ○ D ○

9 A ○ B ○ C ○ D ○

10 A ○ B ○ C ○ D ○

11 A ○ B ○ C ○ D ○

12 A ○ B ○ C ○ D ○

13 A ○ B ○ C ○ D ○

14 A ○ B ○ C ○ D ○

15 A ○ B ○ C ○ D ○

16 A ○ B ○ C ○ D ○

17 A ○ B ○ C ○ D ○

18 A ○ B ○ C ○ D ○

19 A ○ B ○ C ○ D ○

20 A ○ B ○ C ○ D ○

21 A ○ B ○ C ○ D ○

22 A ○ B ○ C ○ D ○

23 A ○ B ○ C ○ D ○

24 A ○ B ○ C ○ D ○

25 A ○ B ○ C ○ D ○

26 A ○ B ○ C ○ D ○

27 A ○ B ○ C ○ D ○

28 A ○ B ○ C ○ D ○

29 A ○ B ○ C ○ D ○

30 A ○ B ○ C ○ D ○

The multiple choice questions are not shown here on No Brain Too Small

Question 1 [2 marks]

The diagram shows a washing machine. When the door is closed and the machine is switched on, an electric motor rotates the drum and clothes.

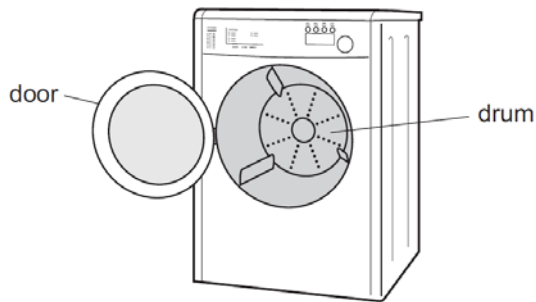

Choose words from the list below to complete the sentences.

chemical • heat • kinetic • light • nuclear • gravitational potential • sound

- (a) In an electric motor, the useful energy transfer is electrical energy into _____ energy.
- (b) Some of the electrical energy supplied to the motor is wasted as _____ energy and _____ energy.

Question 2 [1 mark]

The diagram shows the four types of human tooth.

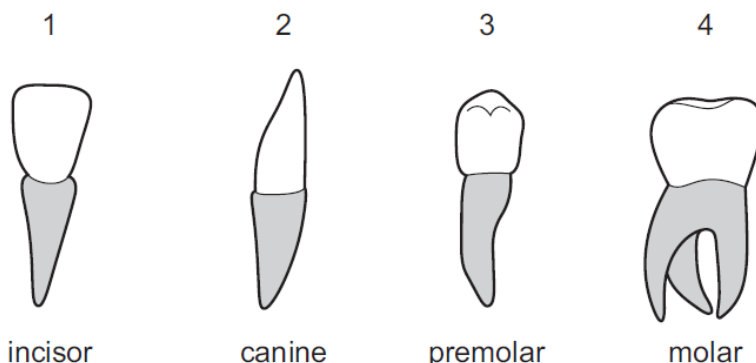

Which teeth are used for cutting rather than grinding food? Circle your answer.

- A 1 and 2
- B 2 and 3
- C 3 and 4
- D 4 and 1

Question 3 [2 marks]

Use the words from the list below to complete the following sentences.

conduction • convection • radiation

- (a) The transfer of heat energy by the movement of hot liquids is called _____
- (b) The transfer of heat energy from one particle to another is called _____

Question 4 [2 marks]

Identical dishes of cress seedlings were put in different conditions as shown in the diagrams in List A. List B shows the possible appearance of each dish of seedlings after a few days.

Draw one line from each condition in List A to the appearance of the seedlings after a few days in List B. (Two pictures in list B won't be needed).

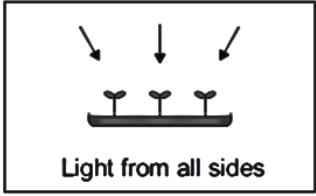
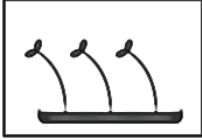
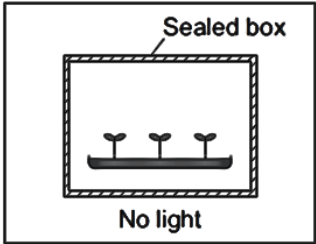
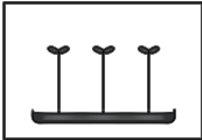
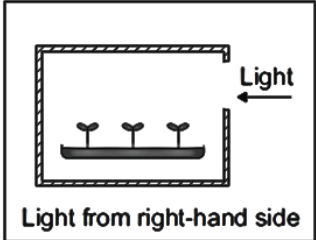
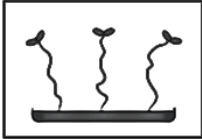
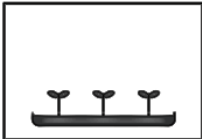
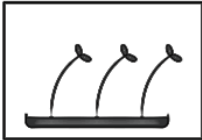
List A Condition	List B Appearance after a few days
	
	
	
	
	

Question 5 [3 marks]

The structure of the Earth has four parts. The outer part is the crust.

(a) Name the other three parts of the Earth.



The Earth's crust is broken into pieces.

(b) Give the name of the pieces of the Earth's crust.

--

Question 6 [3 marks]

Hand warmers use chemical reactions.

The table shows temperature changes for chemical reactions A, B and C.



Reaction	Starting temperature (°C)	Final temperature (°C)	Change in temperature (°C)
A	18	25	+7
B	17		+5
C	18	27	+9

(a) What is the final temperature for reaction B? Write your answer **in the table** above.

(b) Which reaction, A, B or C, would be best to use in a hand warmer?

(c) Give a reason why you chose this reaction.

Question 7 [2 marks]

The diagrams represent the particles in substances X, Y and Z. Identify X, Y and Z as **an element, a compound or a mixture**.

X

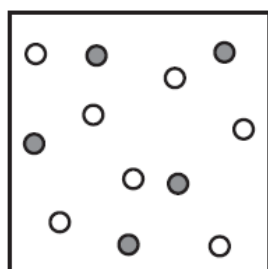

Y

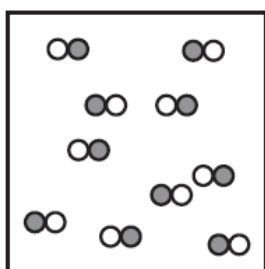

Z

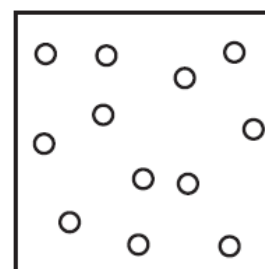

--	--	--

Question 8 [3 marks]

In the Grand Canyon, scientists have found fossils of several different groups of organisms. The diagram shows the number and age of the fossils that the scientists found. The width of each shaded area shows the number of fossils found.

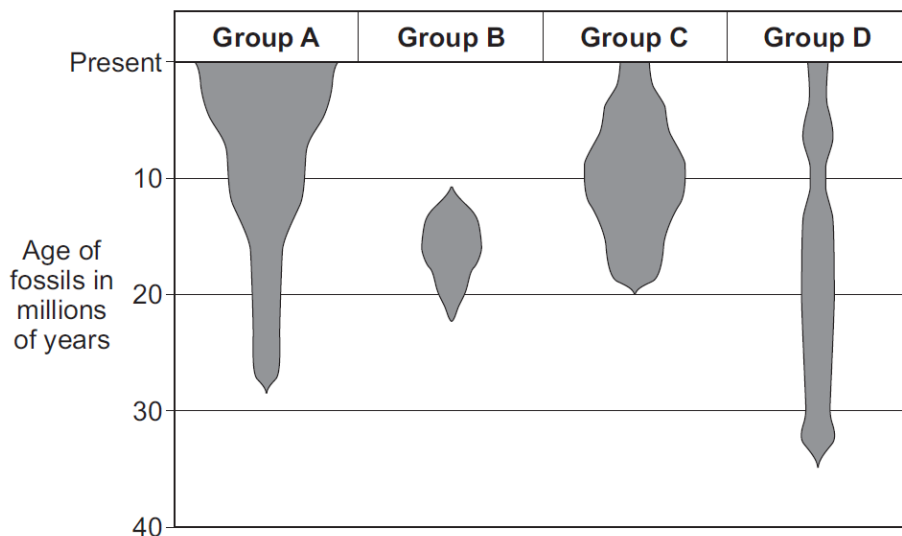

(a) What is a fossil?

(b) Which group of organisms, A, B, C or D, was the first seen (was the oldest)?

--

(c) Which group of organisms, A, B, C or D, is now extinct?

--

Question 9 [2 marks]

For each part of the digestive system in the list below, tick the correct function or functions.

part	ingestion	digestion	absorption
mouth	<input type="checkbox"/>	<input type="checkbox"/>	<input type="checkbox"/>
stomach	<input type="checkbox"/>	<input type="checkbox"/>	<input type="checkbox"/>
small intestine	<input type="checkbox"/>	<input type="checkbox"/>	<input type="checkbox"/>

Question 10 [6 marks]

The table shows some of the nutrients contained in 100 g of five foods.

food	nutrients			
	sugar/g	starch/g	protein/g	fat/g
A	0	0	13	10
B	14	6	7	0
C	0	0	14	6
D	6	8	12	14
E	9	14	3	0

(a) Circle the **two nutrients** listed in the table that are carbohydrates?

protein ● fat ● sugar ● starch



(b) Which **nutrient** listed in the table contains nitrogen atoms in its molecules?

(c) Animal products do not contain carbohydrates. Give the letters of **two foods** in the table that could have come from animals.

(d) Give the letter of **one food** that would appear orange-brown when tested with iodine solution, **and** give a purple colour when tested with biuret reagent.

A hospital dietician advised a patient to eat food containing lots of protein. Protein is an important nutrient in our diet.

(e) Tick (✓) two boxes which show foods that contain a lot of protein.

				
Apples	Bread	Cheese	Milk	Potatoes
<input type="checkbox"/>	<input type="checkbox"/>	<input type="checkbox"/>	<input type="checkbox"/>	<input type="checkbox"/>

(f) What is the function of protein in the diet? Put a tick (✓) in the box next to the correct answer.

- | | | |
|--|---|---|
| <input type="checkbox"/> To provide insulation | <input type="checkbox"/> To repair body tissues | <input type="checkbox"/> To allow the blood to clot |
|--|---|---|

Question 11 [2 marks]

The diagram below shows an insect-pollinated flower cut in half.

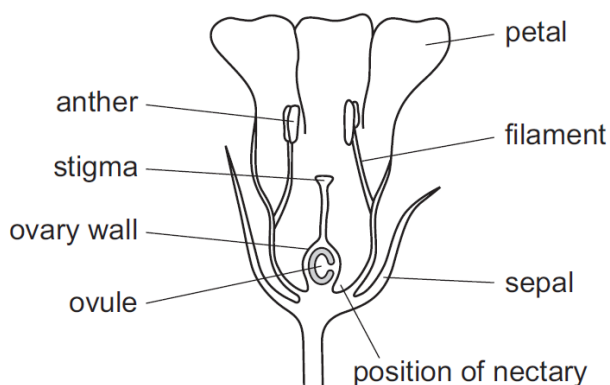

(a) List the structures, labelled in the diagram, that are the **male parts** of the flower.

(b) List the structures, labelled in the diagram, that are the **female parts** of the flower.

Question 12 [3 marks]

On the cheque below it is suspected that Mr. Smith has added eighty to the value of the cheque.

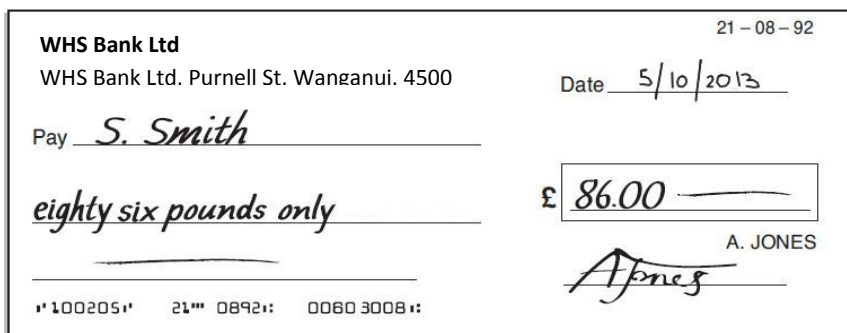

The ink from words 'eighty' and 'six' were tested using chromatography. The results are shown.

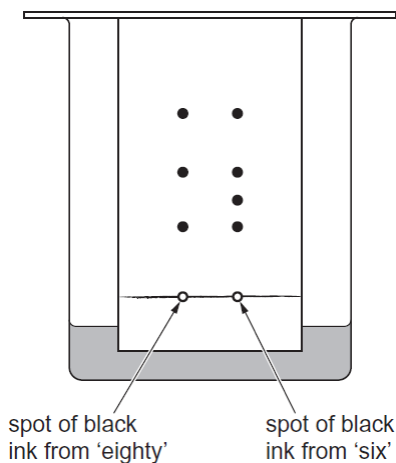

(a) How many dyes did the black ink from the 'eighty' contain?

--

(b) From the results decide if there was a forgery and give a reason for your answer.

Question 13 [1 mark]

A rod is rubbed with a dry piece of cloth. A scientist holds the rod in her hand and brings it close to a negatively charged polythene strip. The strip is suspended by an insulating thread.

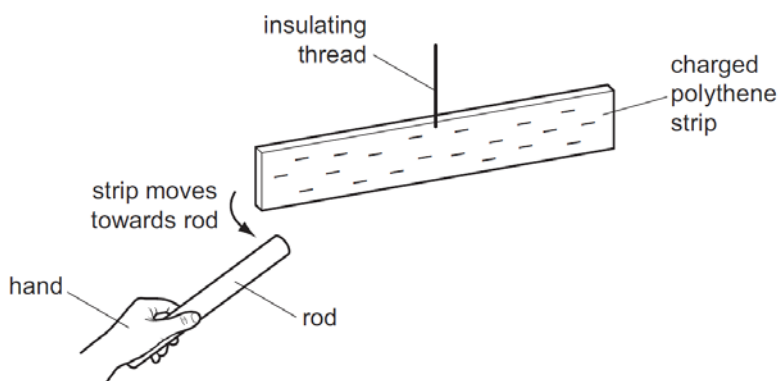

As the rod approaches the polythene strip, the strip moves towards the rod. Which statement is correct? (Circle your answer).

- A The rod is a negatively charged electrical conductor.
- B The rod is a negatively charged electrical insulator.
- C The rod is a positively charged electrical conductor.
- D The rod is a positively charged electrical insulator.

Question 14 [5 marks]

The circuit shows a battery and four lamps. All the lamps are lit. One lamp fails and all the lamps go out.

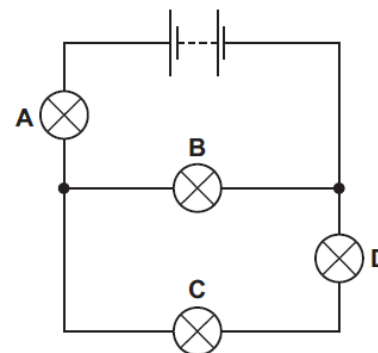

(a) Which lamp failed? (Circle your answer).

A B C D

A student has devised a new circuit to control the lighting of three lamps, A, B and C. More than one switch must be closed in order to light any lamp.

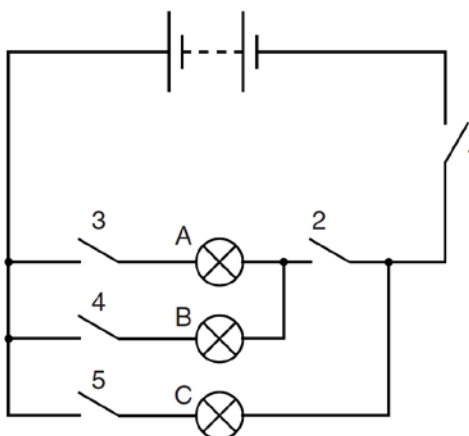

(b) In the table below, put ticks to indicate which switches must be closed in order to light the lamps. The first row has been completed for you.

Lamp that is lit	Switches closed				
	1	2	3	4	5
Lamp A only	✓	✓	✓		
Lamp B only					
Lamp C only					

All the switches are now closed.

(c) Which of the lamps light up?

(d) Which one switch must be open to ensure that none of the lamps light up? Explain your choice.

Question 15 [2 marks]

Three types of blood vessels are **arteries**, **capillaries** and **veins**.

The diagrams show three blood vessels in cross-section, not drawn to the same scale.

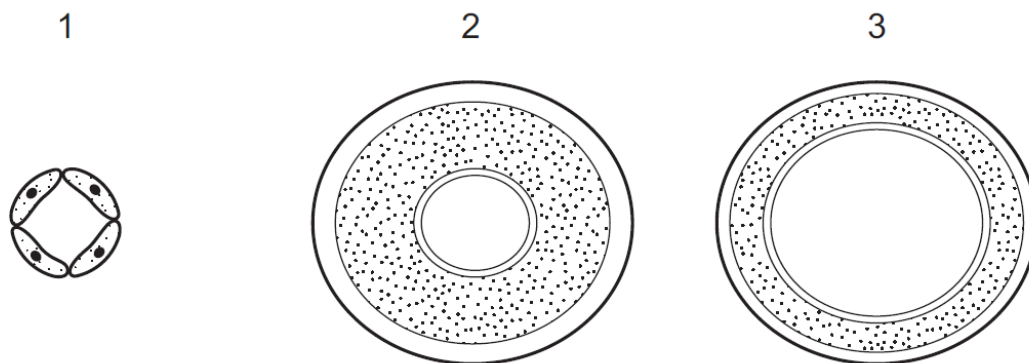

Name these blood vessels.

1	2	3
---	---	---

Question 16 [3 marks]

A Scenes of Crime Officer (SOCO) is one of the first people to examine a crime scene.

(a) Draw a ring around **two** pieces of equipment below that a SOCO might use to collect evidence at a crime scene.



The photograph shows some equipment used by a SOCO.



(b) What would the SOCO use the equipment in the photograph for?

(c) Describe how the SOCO would use this equipment.

Question 17 [2 marks]

Some reactions of a substance, R, are shown in the diagram.

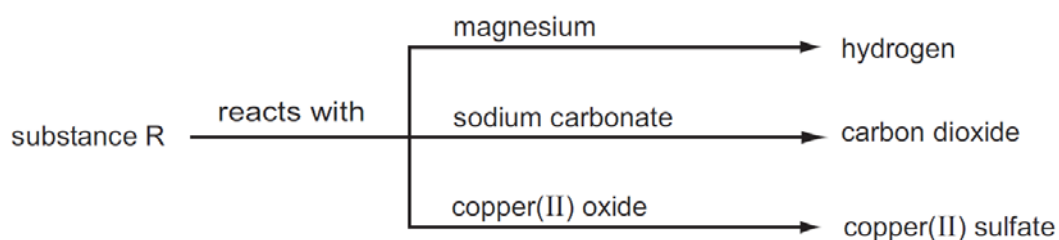

(a) What type of substance is R?

--

(b) Name substance R.

--

Question 18 [2 marks]

The diagram shows the structure of the heart.

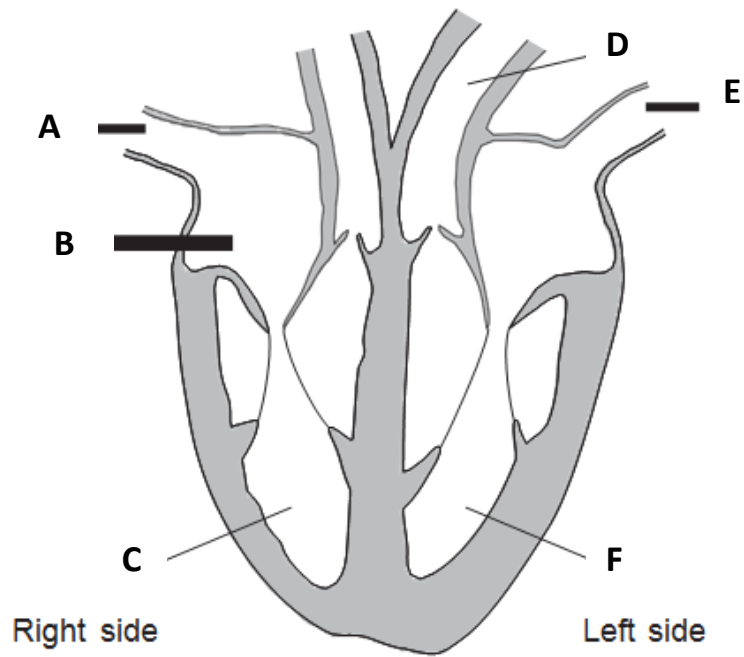

The table shows the names of the parts of the heart and their functions.

Use letters from the diagram to complete the table.

Name of part	Function	Letter
Aorta	Carries blood from the heart	
Vena cava	Carries blood from the body to the heart	
Left ventricle	Pumps blood out of the heart to the body	
Right atrium	Receives blood from the body	

Question 19 [4 marks]

Read the passage and then answer the questions below.

When a volcano erupts, the material that rises to the surface is called magma.

There are two main types of magma—basic magma and silicic magma. Basic magma contains less than 55% silica and is very hot, reaching a temperature of about 1200 °C. Basic magma is fast flowing.

Silicic magma contains between 55% and 70% silica. Silicic magma is slow moving and only reaches temperatures of about 700 °C.

When the magma reaches the surface, it can form lava and hot gases. If the volcano is underwater the lava cools quickly to form rock formations called pillow lava. If the volcano is on land the lava can flow and cool to form layers of volcanic rock.



(a) What temperature is reached by fast flowing basic magma?

(b) Which type of magma contains the higher percentage of silica?

(c) Where would you find volcanoes that form pillow lava?

(d) A type of magma has a silica content of 60%. List two other pieces of information about this magma.

1.
2.



END OF EXAMINATION