

**Level 3 Science** 90730 Describe selected organic compounds and their uses

**Distillation Questions** - Selected Questions from past NCEA papers and discussion

**(NCEA 2007)** Crude oil is a mixture of hydrocarbons of different chain lengths called fractions. To obtain the different hydrocarbons that are used, the mixture needs to be separated into the fractions. This is done in a **fractional distillation column**, as shown in the diagram below.

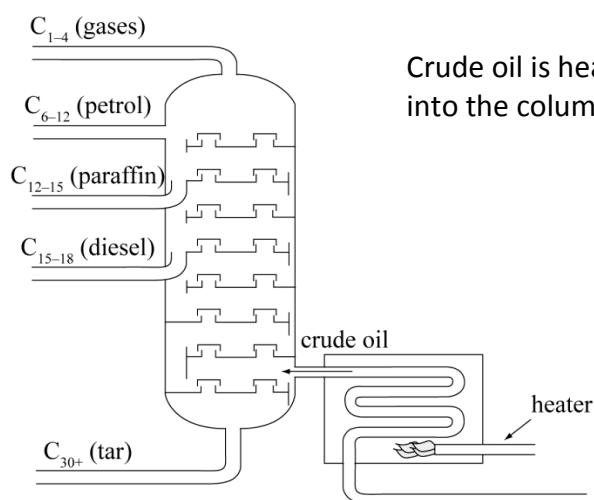

Crude oil is heated to 450°C before it is passed into the column, as indicated in the diagram.

(a)

<p>(i) Name the <b>physical property</b> on which the process of fractional distillation is dependent.</p>	<p><b>Boiling point</b> – crude oil is a mixture of different liquids so they are separated on the basis that they will all have different boiling points.</p>
<p>(ii) Describe the reason the crude oil is <b>heated to 450°C</b></p>	<p>By heating the oil to quite a high temperature it means that <b>all of the different liquids in the mixture will have vapourised</b> (turned into a gas) This is going to allow all of the components of the mixture to easily pass through the distillation column.</p>

(iii) Explain why the crude oil enters the column, as shown in the diagram, and not closer to the bottom where the tar is collected.

The inlet pipe for the crude oil has to be kept clear of the point in the column where the thickest (most viscous) fraction is collected. Since bitumen is the fraction with the longest molecules, they have the highest boiling point and will be the first to condense and be collected. If the inlet pipe was near the point at which bitumen collects we might expect the inlet to clog/ get blocked.

(iv) Discuss why petrol leaves higher up the column than diesel. Consider the length of the hydrocarbon chains and the forces of attraction between them in your answer.

Looking at the diagram provided it tells us that petrol is made up of hydrocarbons with a carbon chain length of between 6 to 12 carbon atoms. These molecules are smaller than those found in the diesel fraction which have longer chains ( 15 to 18 carbon atoms).

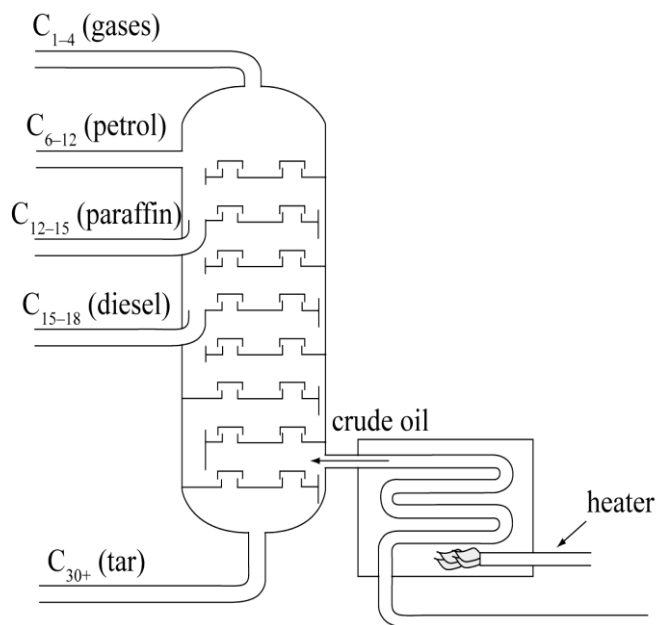

The boiling point of the petrol fraction is lower than diesel because the boiling point is related to the strength of the intermolecular forces between the molecules, which in turn is determined by the size of the molecules.

Smaller molecules have fewer electrons and less surface area – so the temporary dipole – temporary dipole interactions are weaker.

Since petrol has the smaller molecules it will have the weakest intermolecular forces (compared with diesel) and will condense at the point in the tower with the lower temperature (nearer the top). Diesel molecules will condense first as they have stronger intermolecular forces – hence the higher boiling point. Remember a vapour condenses at the same temperature as the liquid boils!!

(b)

A major component of petrol is octane.

Write a balanced symbol equation in the box below for the **complete** combustion of octane.

Octane is an alkane.

Alkanes completely combust to form CO<sub>2</sub> and H<sub>2</sub>O only.

Octane is C<sub>8</sub>H<sub>18</sub> ( use C<sub>n</sub>H<sub>2n+2</sub> for the formula of an alkane)

Start by writing a skeleton equation to show reactants and products



Then start to balance the equation – we know that all of the carbon oxidises to CO<sub>2</sub> – so 8 molecules are produced

And the hydrogen in octane is oxidised to water so 9 molecules of water are produced

Now balance the oxygen atoms on the left hand side – we have 25 atoms of oxygen in the products – so 12.5 molecules of O<sub>2</sub> are needed

To get rid of the 12.5 we multiply the whole equation by two which gives



**Key ideas** - the physical properties of organic molecules (melting and boiling points) are determined the strength of the intermolecular forces between the molecules. These forces are determined by size of molecule and area of molecules. Larger molecules boil and condense at higher temperatures than smaller molecules. This physical property difference is used to separate the mixture of liquids found in crude oil.

In 2010 this question was set in the context of fuels

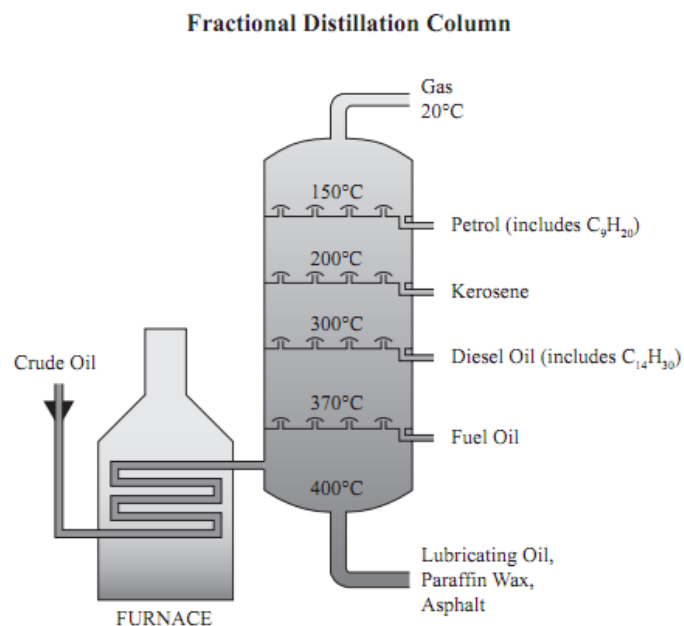

Fractional distillation is a process that separates heated crude oil into its fractions (parts).

One fraction is the petrol fraction, another is the diesel fraction.

Discuss how diesel and petrol fractions are separated out from crude oil. Your answer should include:

- an explanation of how a physical property is used to separate the fractions
- a comparison of the chain lengths of compounds in diesel and petrol
- the relationship between chain length and separation in the fractional distillation column.

As you can see it is very similar to the 2007 question!

Understand the basics and be prepared to apply them in the context of the question you are asked.