

93103



S



*For Supervisor's use only*



NEW ZEALAND QUALIFICATIONS AUTHORITY  
MANA TOHU MĀTAURANGA O AOTEAROA

## Scholarship 2008 Physics

9.30 am Saturday 29 November 2008

Time allowed: Three hours

Total marks: 48

Check that the National Student Number (NSN) on your admission slip is the same as the number at the top of this page.

You should answer ALL the questions in this booklet.

Write all your answers in this booklet.

For all 'describe' or 'explain' questions, the answers should be written or drawn clearly with all logic fully explained.

For all numerical answers, full working must be shown and the answer must be rounded to the correct number of significant figures and given with the correct SI unit.

**Formulae you may find useful are given on page 2.**

If you need more space for any answer, use the page(s) provided at the back of this booklet and clearly number the question.

Check that this booklet has pages 2–26 in the correct order and that none of these pages is blank.

You are advised to spend approximately 30 minutes on each question.

**YOU MUST HAND THIS BOOKLET TO THE SUPERVISOR AT THE END OF THE EXAMINATION.**

The formulae below may be of use to you.

|   |  |   |
|---|--|---|
| $F_g = \frac{GMm}{r^2}$ $F_c = \frac{mv^2}{r}$ $\Delta p = F\Delta t$ $\omega = 2\pi f$ $d = r\theta$ $v = r\omega$ $a = r\alpha$ $W = Fd$ $F_{\text{net}} = ma$ $p = mv$ $\omega = \frac{\Delta\theta}{\Delta t}$ $\alpha = \frac{\Delta\omega}{\Delta t}$ $L = I\omega$ $L = mvr$ $\tau = I\alpha$ $\tau = Fr$ $E_{K(\text{ROT})} = \frac{1}{2}I\omega^2$ $E_{K(\text{LIN})} = \frac{1}{2}mv^2$ $\Delta E_p = mgh$ $\omega_f = \omega_i + \alpha t$ $\omega_f^2 = \omega_i^2 + 2\alpha\theta$ $\theta = \frac{(\omega_i + \omega_f)t}{2}$ $\theta = \omega_i t + \frac{1}{2}\alpha t^2$ | $T = 2\pi\sqrt{\frac{l}{g}}$ $T = 2\pi\sqrt{\frac{m}{k}}$ $E_p = \frac{1}{2}ky^2$ $F = -ky$ $a = -\omega^2 y$<br>$y = A\sin\omega t \quad y = A\cos\omega t$ $v = A\omega\cos\omega t \quad v = -A\omega\sin\omega t$ $a = -A\omega^2\sin\omega t \quad a = -A\omega^2\cos\omega t$<br>$\Delta E = Vq$ $P = VI$ $V = Ed$ $Q = CV$ $C_T = C_1 + C_2$ $\frac{1}{C_T} = \frac{1}{C_1} + \frac{1}{C_2}$ $E = \frac{1}{2}QV$ $C = \frac{\epsilon_o \epsilon_r A}{d}$ $\tau = RC$ $\frac{1}{R_T} = \frac{1}{R_1} + \frac{1}{R_2}$ $R_T = R_1 + R_2$ $V = IR$ $F = BIL$ | $\phi = BA$ $\epsilon = -\frac{\Delta\phi}{\Delta t}$ $\epsilon = -L\frac{\Delta I}{\Delta t}$ $\epsilon = -M\frac{\Delta I}{\Delta t}$ $\frac{N_p}{N_s} = \frac{V_p}{V_s}$ $E = \frac{1}{2}LI^2$ $\tau = \frac{L}{R}$ $I = I_{\text{MAX}}\sin\omega t$ $V = V_{\text{MAX}}\sin\omega t$ $I_{\text{MAX}} = \sqrt{2}I_{\text{rms}}$ $V_{\text{MAX}} = \sqrt{2}V_{\text{rms}}$ $X_C = \frac{1}{\omega C}$ $X_L = \omega L$ $V = IZ$ $n\lambda = \frac{dx}{L}$ $n\lambda = d\sin\theta$ $f' = f\frac{V_w}{V_w \pm V_s}$ $E = hf$ $hf = \phi + E_K$ $E = \Delta mc^2$ $\frac{1}{\lambda} = R\left(\frac{1}{S^2} - \frac{1}{L^2}\right)$ $E_n = -\frac{hcR}{n^2}$ $v = f\lambda$ $f = \frac{1}{T}$ |
|---|--|---|

This page has been deliberately left blank.





**QUESTION TWO: THE WINE BUTLER (8 marks)**Assessor's  
use only

The “Wine Butler” is a simple device, usually made of wood or plastic, that is used to hold a bottle of wine in an attractive and interesting manner. The neck of the wine bottle is placed through a hole in the wine butler, and the butler is set at an angle so that the whole assembly is balanced, as shown.



The wine butler has a length of  $2L$  and it can be assumed that its centre of mass is in the middle,  $L$  from either end. In the diagram, the distances from the top of the hole to the centres of mass of the bottle and the butler are indicated, along with the horizontal distances from the respective centres of mass to the point of balance,  $O$ .

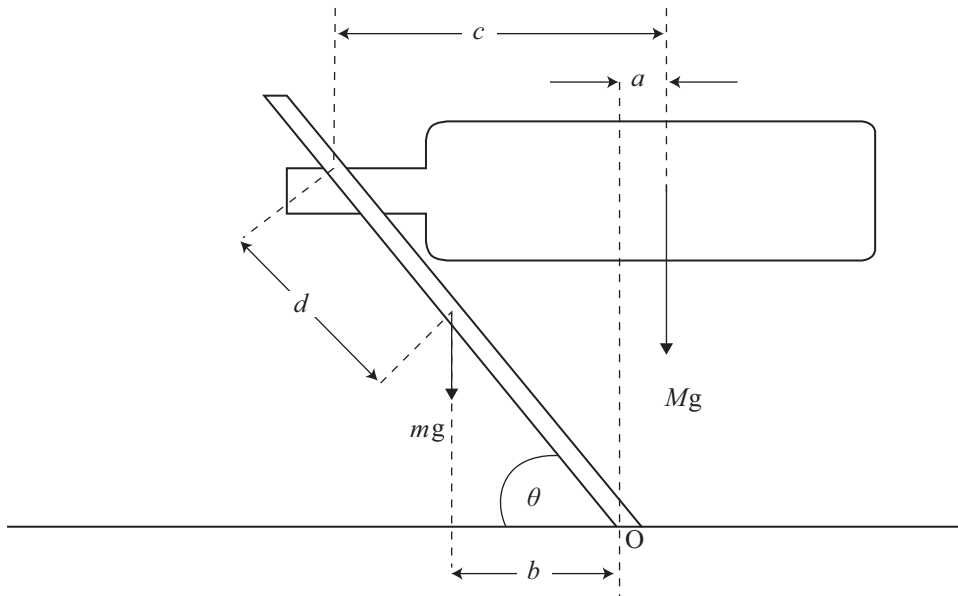

- (a) (i) By taking torques, show that the wine butler is in rotational equilibrium if:

$$\frac{b}{a} = \frac{M}{m}$$

---



---



---



- (d) After the contents of the bottle have been removed, can the bottle be replaced in the same equilibrium position or must the neck of the bottle be moved to the left or right? (Assume that the centre of mass of the bottle stays in the same place when the wine is removed.)

---

---

---

---

---

---

---

---

Assessor's  
use only



This page has been deliberately left blank.

**QUESTION THREE: THE PHYSICS OF THE SWING (8 marks)**

Acceleration due to gravity =  $9.80 \text{ m s}^{-2}$

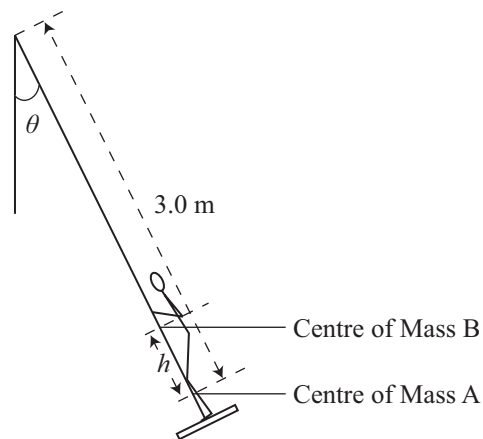
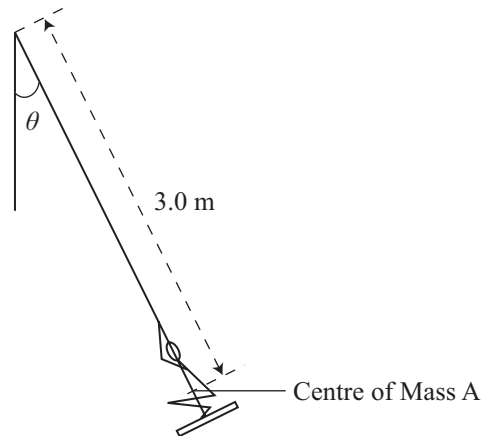

Kristina is playing on a swing. She knows that she can alter the amplitude of the swing by changing her position at various stages of the swing cycle. Initially, Kristina is squatting on the swing, with her feet on the seat, as shown in the top figure.

- (a) When the swing is at angle  $\theta$ , Kristina stands up so that her centre of mass changes by a distance  $h$  (from A to B), as shown in the bottom figure.

Show that Kristina gains gravitational potential energy of  $mgh \cos\theta$ .

---



---



---

(b) When Kristina stands she notices that the swing picks up speed.

(i) Explain why the speed increases.

---

---

---

---

---

---

---

---

---

---

(ii) Explain whereabouts in the motion Kristina should stand up in order to gain the maximum kinetic energy.

---

---

---

---

---

---

---

---

---

---

Assessor's  
use only





**QUESTION FOUR: THE DOPPLER EFFECT (8 marks)**Assessor's  
use only

- (a) A class experiment was set up to investigate the Doppler effect for sound. Two speakers facing forwards and backwards respectively, were mounted on the roof of a car and connected to a signal generator set to a frequency of 1500 Hz.

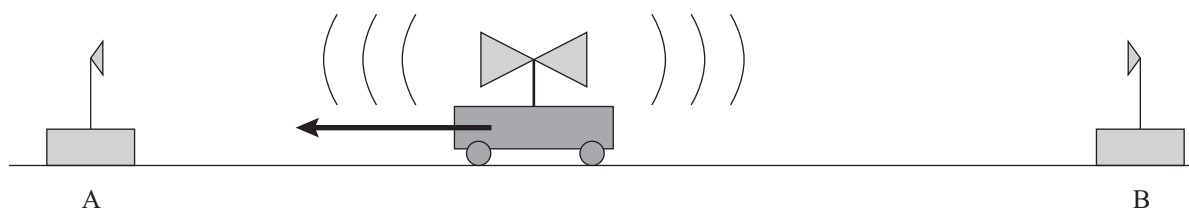

Two microphones, A and B, one placed forward of the car and the second placed to the rear of the car, were used to detect the sound of the speakers. Each microphone was connected to an instrument that measured the frequency of the received sound. With the car moving towards detector A several runs were made at different speeds. Prior to the experiment the class made a table of the expected frequency measurements, as shown below (the speed of sound was assumed to be  $340 \text{ m s}^{-1}$ ).

| Speed / $\text{m s}^{-1}$ | Predicted frequency / Hz |               | Actual frequency / Hz |               |
|---------------------------|--------------------------|---------------|-----------------------|---------------|
|                           | A<br>Column 2            | B<br>Column 3 | A<br>Column 4         | B<br>Column 5 |
| 0                         | 1500                     | 1500          | <b>1500</b>           |               |
| 10                        | 1545                     | 1455          | <b>1545</b>           |               |
| 20                        | 1594                     | 1406          | <b>1594</b>           |               |

- (i) The class's predictions for microphone A, calculated from a formula, are shown in column 2. Based on these results, the class write down predictions for microphone B (column 3).

In doing this, what assumption has the class made?

---



---

- (ii) By using an appropriate formula, calculate the actual frequencies observed at B (column 5).

---



---



---



---



**QUESTION FIVE: ARMAGEDDON** (8 marks)Assessor's  
use only

Universal gravitational constant =  $6.67 \times 10^{-11} \text{ N m}^2 \text{ kg}^{-2}$

The volume of a sphere =  $\frac{4}{3}\pi r^3$

The movie “Armageddon” is based on an asteroid “the size of Texas”, which is about to collide with the Earth. To protect the Earth, NASA proposes to land a drilling team on the asteroid, who will drill a hole to the centre and detonate a nuclear warhead there. This blast is supposed to split the asteroid into two equal pieces that will each move far enough sideways to safely miss the Earth. However, there is not much time and the explosion will take place only four hours before impact.

- (a) NASA scientists expect that the blast will not affect the motion of the centre of mass.

Explain.

---



---



---

- (b) Using the information and diagram below, work out if the Earth will be saved. Ignore any gravitational attraction between the two lumps, and list any other assumptions you make during your calculation.

Width of Texas =  $1.45 \times 10^6 \text{ m}$   
 Average density of the asteroid =  $3000 \text{ kg m}^{-3}$   
 Energy released by the nuclear warhead =  $5 \times 10^{18} \text{ J}$   
 (this is equivalent to  $10^5$  Hiroshima bombs)

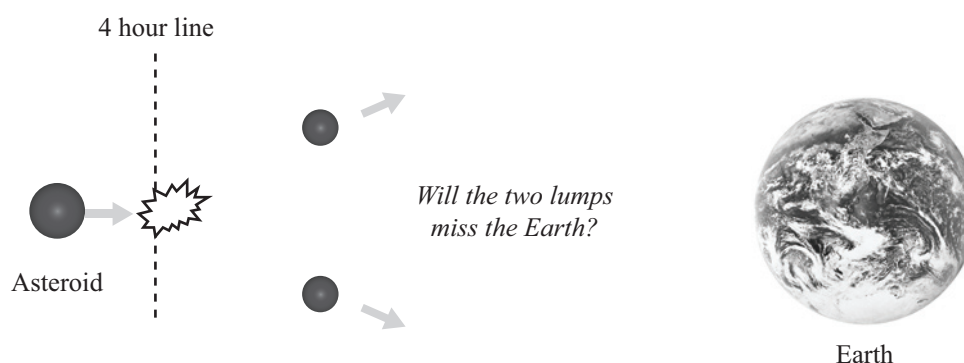

---



---



---



---



---



---





**QUESTION SIX: DC ELECTRICITY (8 marks)**

(a) Kirchhoff's Laws are often used in complex circuits and are written as:

- The potential differences around a closed loop sum to zero.
- The currents entering and leaving a junction sum to zero.

(i) Explain the underlying physical meaning of each law.

Kirchhoff's Potential Difference Law

---



---

Kirchhoff's Current Law

---



---

(ii) In the circuit shown below, what is the current in the  $8\ \Omega$  resistor?

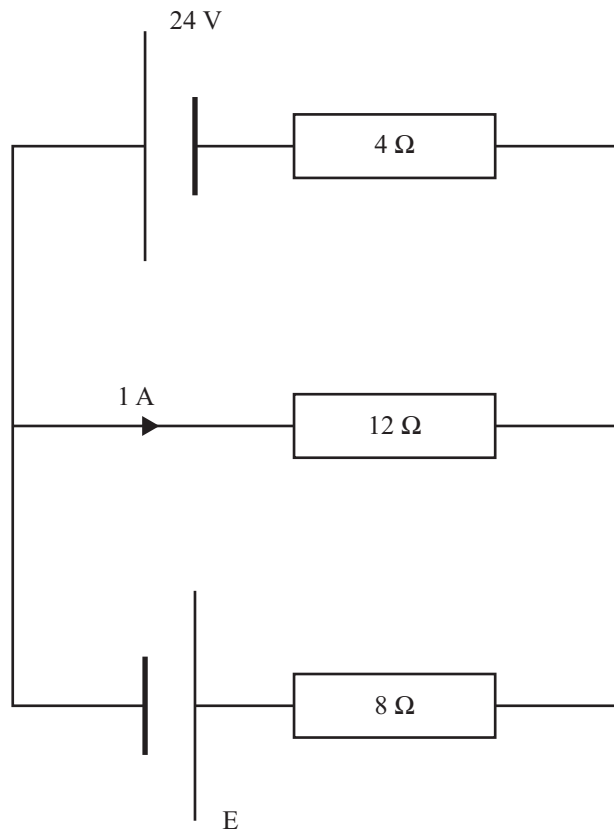

- (b) In the circuit below, switch S is initially open and the capacitors are uncharged.

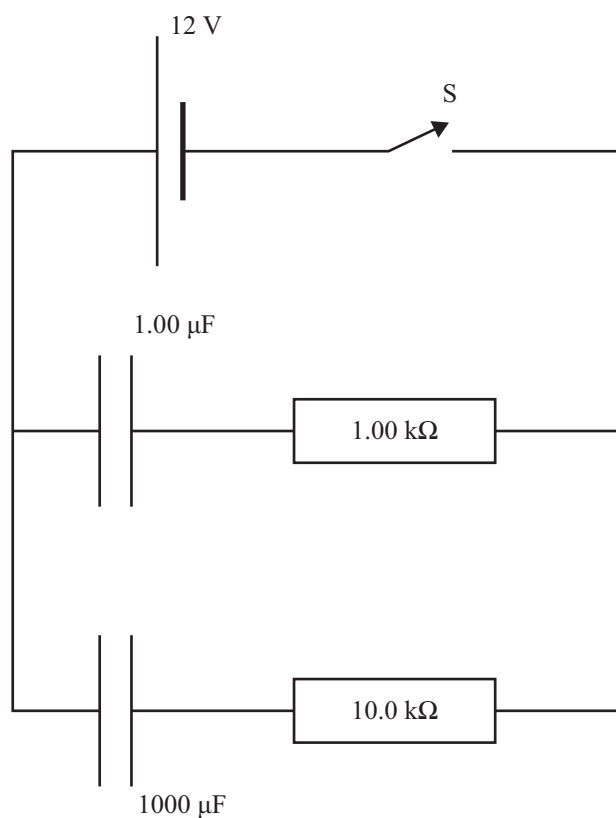

- (i) S is closed at  $t = 0$ .

Discuss how the potential differences across the  $1.00 \text{ k}\Omega$  and the  $10.0 \text{ k}\Omega$  resistors change with time, carefully explaining any differences between them.

---

---

---

---

---

---

---

---

















**For Assessor's use only.  
Keep flap folded in.**

| <b>For Assessor's Use Only</b> |             |
|--------------------------------|-------------|
| Question Number                | Marks       |
| ONE                            | (8)         |
| TWO                            | (8)         |
| THREE                          | (8)         |
| FOUR                           | (8)         |
| FIVE                           | (8)         |
| SIX                            | (8)         |
| <b>TOTAL</b>                   | <b>(48)</b> |